

Goodmans 12 inch range

Axioms

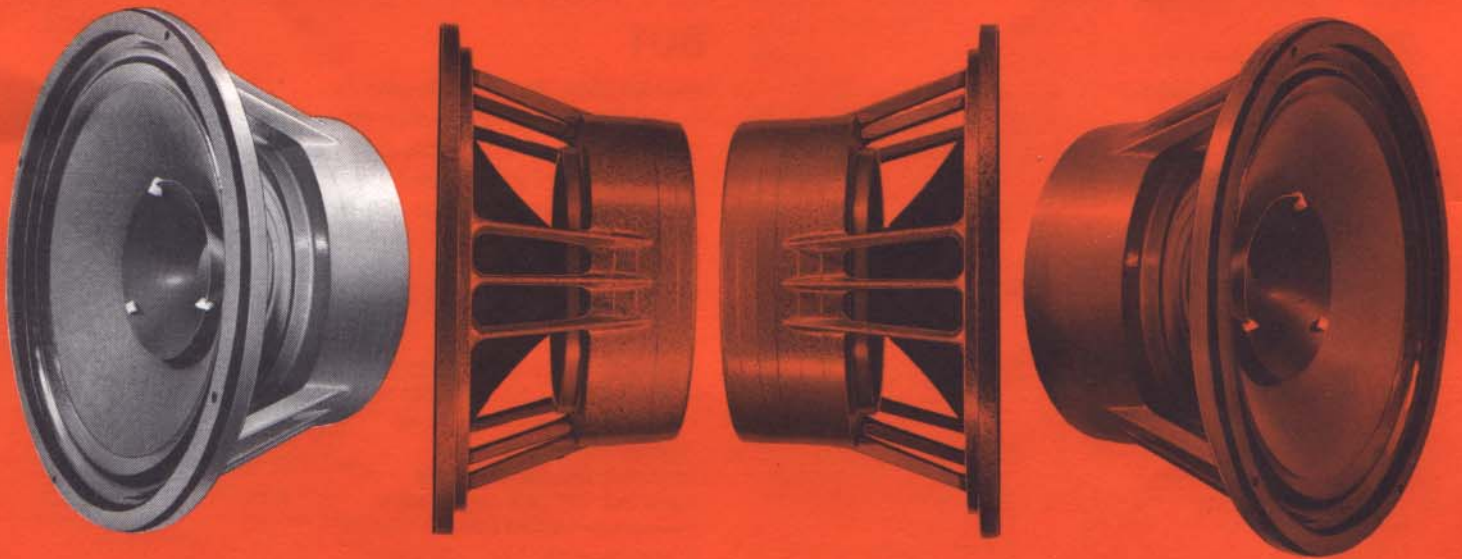

Audioms

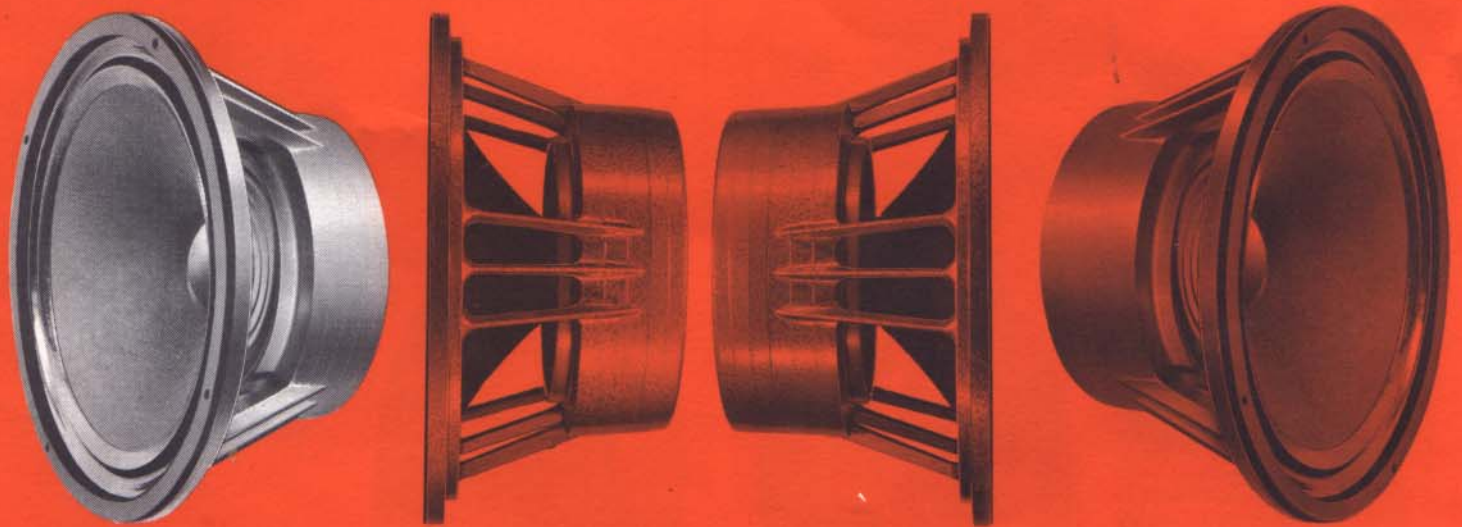

Axioms 12"

Twin Diaphragm

The 12 inch Axiom High Fidelity Loudspeakers are world famous. Their extended range and richness of reproduction give them an envied reputation as 'Loudspeakers to live with'. This has been achieved by strict attention to essentials and the incorporation of the very latest advances in acoustic design with the advantages of outstanding smoothness, excellent transient handling and very low distortion, over a frequency range of 30–16,000 Hz.

Axiom 301 and **Axiom 201** are twin diaphragm loudspeakers with an automatic crossover from the 12 inch Bass cone to the smaller plastic terminated inner cone.

- The Bass cone now has a pure plastic roll suspension; this gives great strength and excellent acoustic termination,

Impedances now available 15–16 ohms or 8 ohms. Please specify when ordering.

and allows long and linear excursion, reducing distortion to new low limits. Additional advantages of the exacting cone specification are the prevention of standing waves and spurious resonances.

- The moving assembly is driven by a long-throw voice-coil suspended in a massive FERObA II magnet system.
- A one-piece solid felt gasket ensures air-tight mounting and greatly assists in cabinet assembly by taking up baffle board irregularities.

- The entire unit is mounted in a sleek pressure die-cast chassis of new design with open construction and high rigidity to give positive alignment of all parts and to minimise chassis resonances.

- The overall finish is in a smart new hammered grey.

201

The AXIOM 201 handles 15 Watts (30 Watts U.S.A.) of power, and has all the structural advantages of the AXIOM 301. Powerful FERObA II magnet, gap flux density 13,000 gauss (87,500 maxwells).

Specification

Frequency range: 30 – 16,000 Hz

Power handling: 15 Watts (30 Watts U.S.A.)

Fundamental resonance: 35 Hz

Flux density: 13,000 gauss

Total flux: 87,500 maxwells

Voice Coil: 1 $\frac{3}{4}$ " (4.4 cm) diameter

Impedance: 15 – 16 ohms or 8 ohms

Overall diameter: 12 $\frac{1}{4}$ " (31.2 cm)

Overall depth: 5 $\frac{3}{4}$ " (14.8 cm)

ARU 172 enclosure volume (internal): 7,800 cu. ins.

Baffle hole diameter: 11" (28 cm)

Fixing holes: 4 holes 0.312" (0.8 cm) diameter equally spaced on a circle of 11 $\frac{3}{4}$ " (29.8 cm) diameter

Nett weight: 10 lbs 14 ozs (4.93 kg)

301

The AXIOM 301 handles 20 Watts (40 Watts U.S.A.) of power and enjoys a sensitivity coupled with very low distortion that makes it the first choice for top quality higher powered monophonic and stereophonic reproduction. It is also the ideal speaker for the 'add on' Stage Built System, full details of which are given in Goodmans High Fidelity Manual, free on request. The massive FERObA II magnet has a gap flux density of 16,500 gauss (185,000 maxwells).

Specification

Frequency range: 30 – 16,000 Hz

Power handling: 20 Watts (40 Watts U.S.A.)

Fundamental resonance: 35 Hz

Flux density: 16,500 gauss

Total flux: 185,000 maxwells

Voice coil: 1 $\frac{3}{4}$ " (4.4 cm) diameter

Impedance: 15 – 16 ohms or 8 ohms

Overall diameter: 12 $\frac{1}{4}$ " (31.2 cm)

Overall depth: 6 $\frac{1}{2}$ " (15.9 cm)

ARU 172 enclosure volume (internal): 7,800 cu. ins.

Baffle hole diameter: 11" (28 cm)

Fixing holes: 4 holes 0.312" (0.8 cm) diameter equally spaced on a circle of 11 $\frac{3}{4}$ " (29.8 cm) diameter

Nett weight: 17 lbs 5 ozs (7.85 kg)



Audioms 12"

Single Diaphragm

- For High Fidelity (with Midax and Trebax) – ask for the **Bass** version (35 Hz).

- For Electric Guitar and other musical instrument amplification and for strenuous public address work – ask for the **Standard** version (50 Hz).

The **Audiom** 12 inch loudspeakers have been specially built for maximum reliability and efficiency, incorporating the very latest advances in acoustic design.

- New pure plastic roll suspension for the moving assembly, providing great strength and excellent acoustic termination,

51

Power Handling 15 watts (30 watts U.S.A.).

Powerful FERObA II magnet – gap flux density 13,000 gauss (87,500 maxwells).

HIGH FIDELITY SYSTEMS

Suitable for 15 watt three-way systems with Midax and Trebax complete, but not for Stage-Building – ask for the 35 Hz AUDIOM 51 BASS.

For PUBLIC ADDRESS work – ask for the 50 Hz AUDIOM 51 STANDARD.

Specification

Power handling: 15 Watts (30 Watts U.S.A.)

Fundamental resonance: 35 Hz

Flux density: 13,000 gauss

Total Flux: 87,500 maxwells

Voice Coil: 1 $\frac{3}{4}$ " (4.4 cm) diameter

Impedance: 15 – 16 ohms or 8 ohms

Chassis: Diecast

Overall diameter: 12 $\frac{1}{4}$ " (31.2 cm)

Overall depth: 5 $\frac{3}{4}$ " (14.8 cm)

ARU 172 enclosure volume (internal): 7,800 cu. ins.

Baffle hole diameter: 11" (28 cm)

Fixing holes: 4 holes 0.312" (0.8 cm) diameter equally spaced on a circle of 11 $\frac{3}{4}$ " (29.8 cm)

Nett weight: 10 lbs 13 ozs (4.9 kg)

Impedances now available 15–16 ohms or 8 ohms. Please specify when ordering.

and allowing long and linear excursion reducing distortion to new low limits.

- The moving assembly is driven by a long throw voice-coil suspended in a massive FERObA II magnet system.

- One-piece solid felt gasket ensures air-tight mounting and greatly assists in cabinet assembly by taking up baffle board irregularities.

- New sleek pressure diecast chassis of open construction and high rigidity to give positive alignment of all parts, and to minimise chassis resonances.

- New smart hammered grey finish.

61

Power Handling 20 watts (40 watts U.S.A.).

Massive FERObA II magnet – gap flux density 16,500 gauss (185,000 maxwells).

Ideal as the Bass unit in the three-way system (with Midax and Trebax when this is built complete from the start and NOT Stage-Built) – ask for the 35 Hz AUDIOM 61 BASS. The AUDIOM 61 STANDARD is a hard-working, tough loudspeaker which is ideal for Public Address systems – such as in Stadiums, Sports Grounds, etc., where reliability is of paramount importance – ask for the 50 Hz AUDIOM 61 STANDARD.

For Electric Guitar work ask for Goodmans Guitar leaflet.

Specification

Power handling: 20 Watts (40 Watts U.S.A.)

Fundamental resonance: 35 Hz

Flux density: 16,500 gauss

Total flux: 185,000 maxwells

Voice Coil: 1 $\frac{3}{4}$ " (4.4 cm) diameter

Impedance: 15 – 16 ohms or 8 ohms

Chassis: Diecast

Overall diameter: 12 $\frac{1}{4}$ " (31.2 cm)

Overall depth: 6 $\frac{1}{4}$ " (15.9 cm)

ARU 172 enclosure volume (internal): 7,800 cu. ins.

Baffle hole diameter: 11" (28 cm)

Fixing holes: 4 holes 0.312" (0.8 cm) diameter equally spaced on a circle of 11 $\frac{3}{4}$ " (29.8 cm) diameter

Nett weight: 17 lbs 4 ozs (7.82 kg)



Complete 3-way High Fidelity System

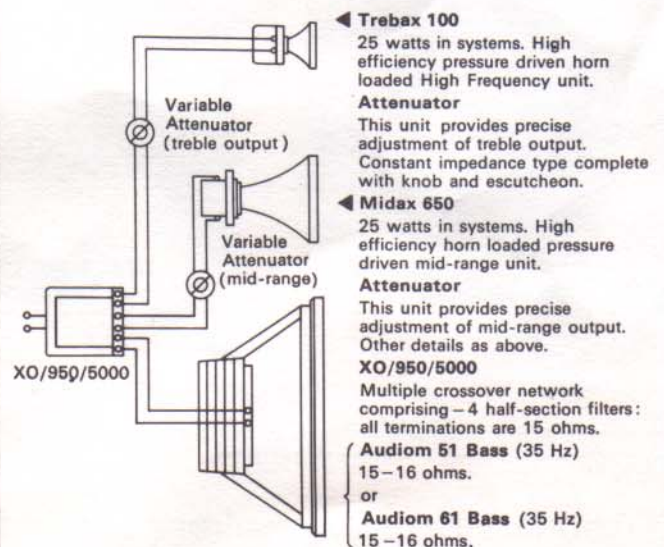

Recommended Enclosures

For Axioms 201 and 301, Audioms 51 and 61.

A.R.U. 172 Enclosure (with A.R.U. 172) – 7,800 cu. ins.

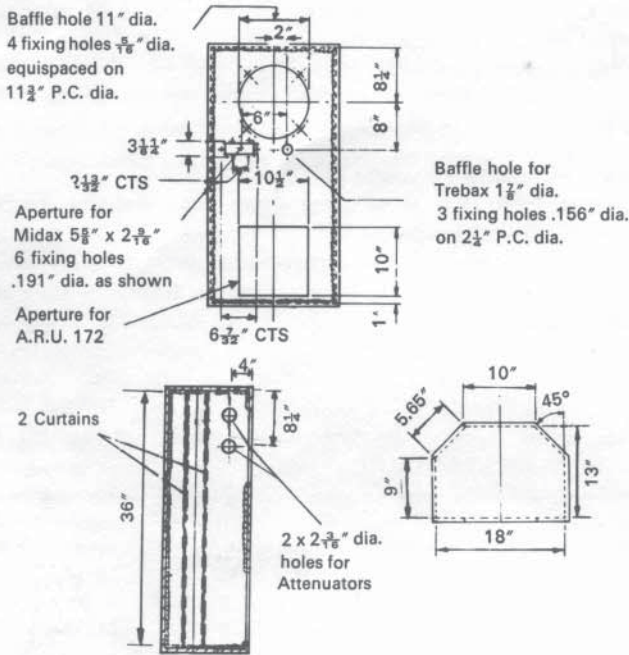

Sherwood Type Enclosure (with A.R.U. 172) – 7,800 cu. ins.

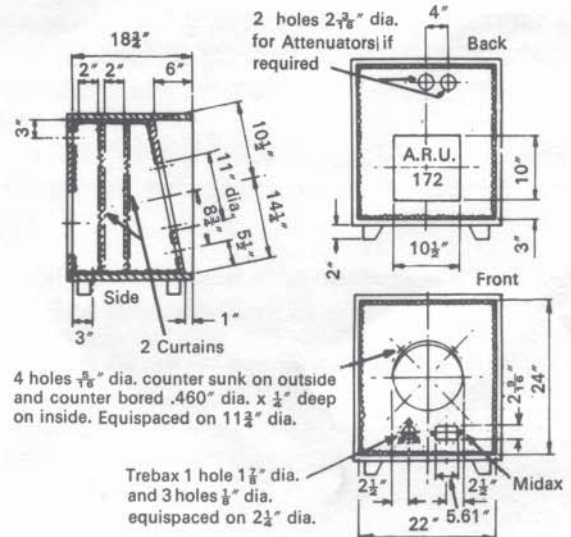

All Enclosures should be rigidly constructed of timber or chipboard preferably 7/8" thick but not less than 3/4" thick interiors to be lined with 1" thick wadding except speaker and reflex aperture.

ARU 172. This is a patented enclosure loading device and is for use with enclosures with an internal volume of 7,800 cubic inches.

Rectangular Reflex Cabinet (without A.R.U.) – 12,500 cu. ins.

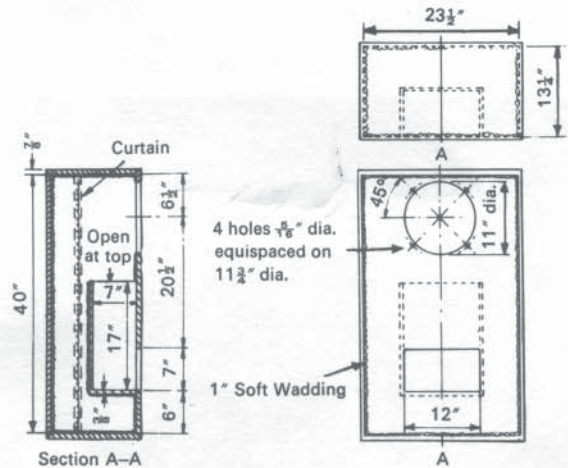

The descriptions in this publication are correct at the time of going to press. However, we reserve the right to make alterations, without notice, resulting from continuing development.

Goodmans Loudspeakers Limited

Axiom Works, Wembley, Middlesex. Telephone: 01-902 1200

PN85173b

Designed and printed in England