

Bipole Metronome with 2 x CSS EL70

Mass Loaded Quadratic Quarter Wave Tube (ML-QQWT)
concept by Steve Cresswell, designed by D Dlugos & S Lindgren

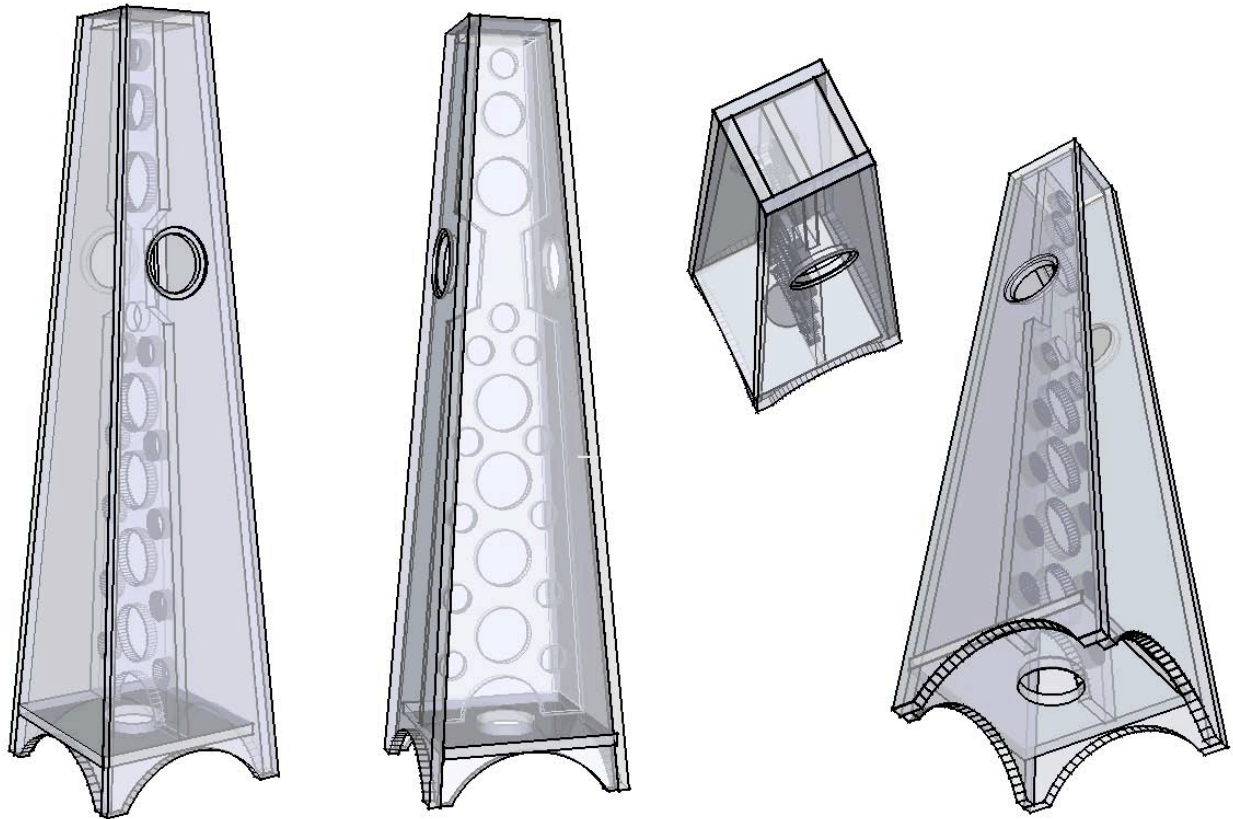

Elegant bipole floorstander utilizing 2 CSS EL70 or Planet10-hifi EL70eN.

- Bipolar radiation means no bafflestep problems
- Large spacious soundstage.
- Quarter wave design gives bass into the high 30s in room
- Optional side mount of 2nd driver if insufficient space to the rear wall

Bipole Metronome
 ML-QQWT for 2 X CSS EL70 ov9
 concept by Steve Cresswell
 designed by D Dlugos & S Lindgren
 09-feb-10 | drawn by dld

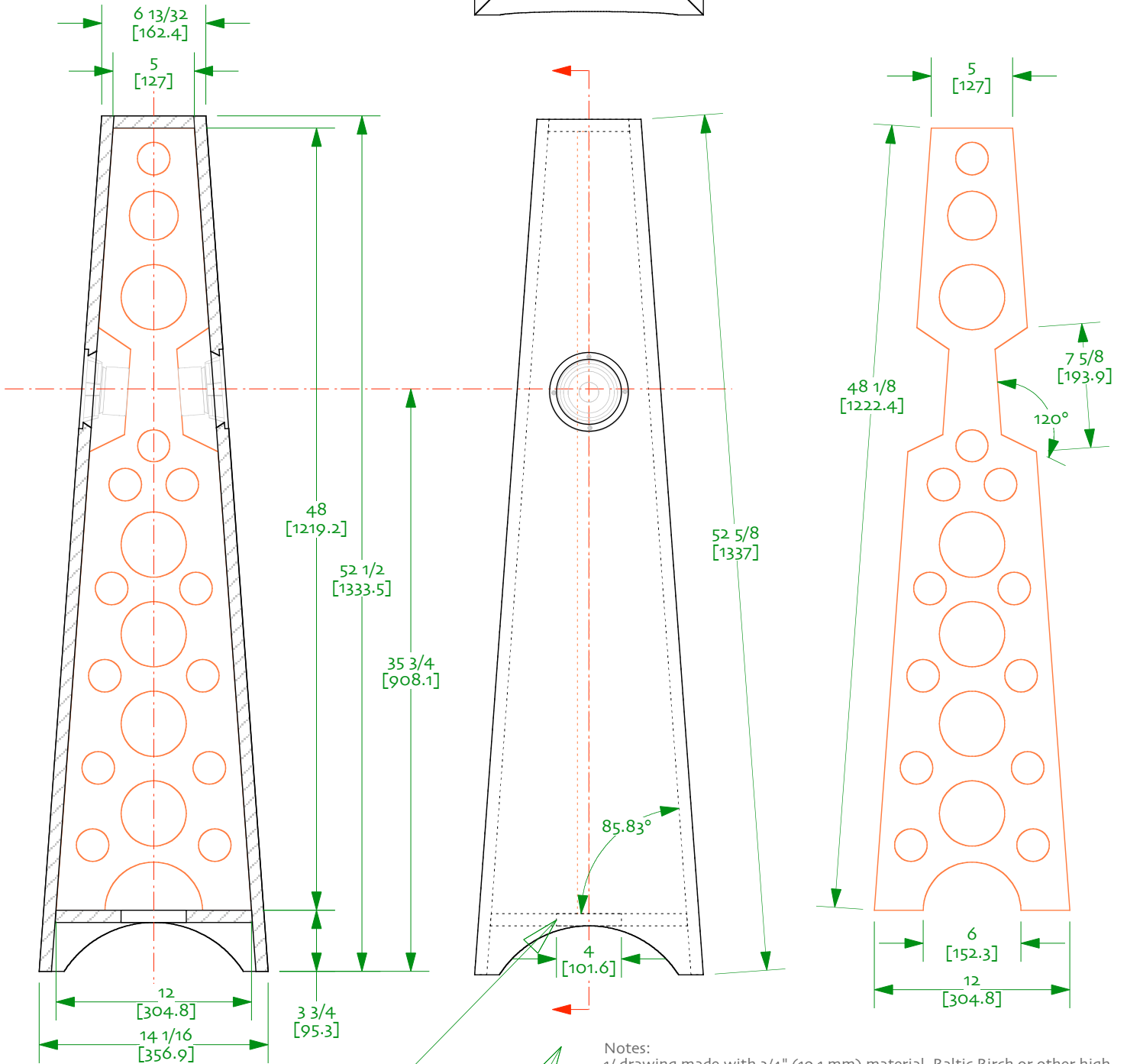
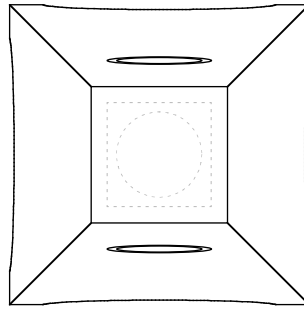

Port is $\frac{3}{4}$ " long (thickness of material in this drawing)

Front width dimensions same as in the side view

- Notes:
- 1/ drawing made with $\frac{3}{4}$ " (19.1 mm) material. Baltic Birch or other high ply plywood recommended
 - 2/ line internal panel behind driver to reduce reflections. Use very little or no other damping in the box to taste – additional damping best placed above driver.
 - 3/ Driver brace should be snug with the speaker's magnet, but not so much as to stress the basket
 - 4/ a round-over or chamfer on the vertical edges is recommended
 - 5/ holes & details of the holey brace are suggestive only
 - 6/ maximum bass requires a hard platform for the speaker to sit on

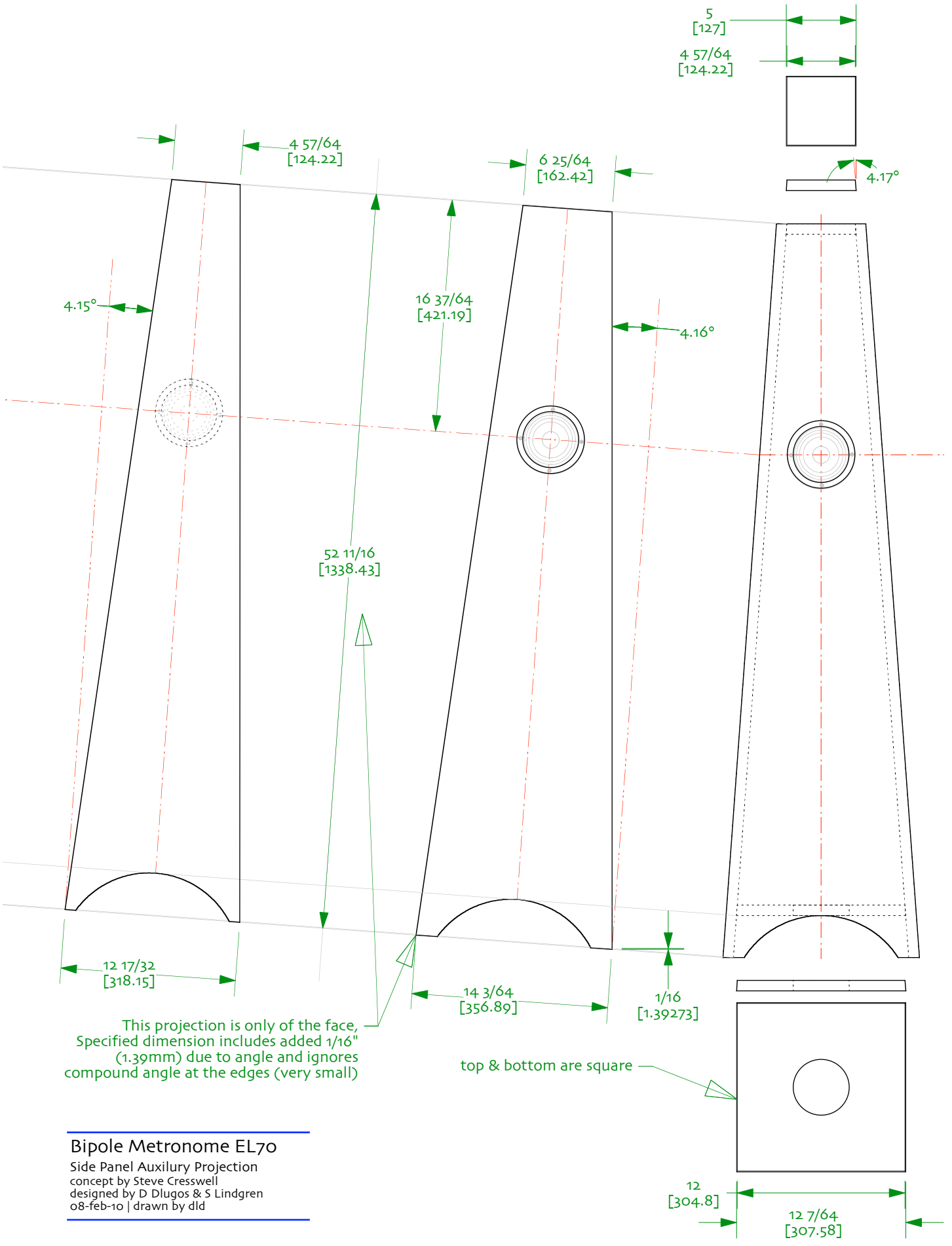

Bipole Metronome EL70
 Side Panel Auxiliary Projection
 concept by Steve Cresswell
 designed by D Dlugos & S Lindgren
 o8-feb-10 | drawn by dld

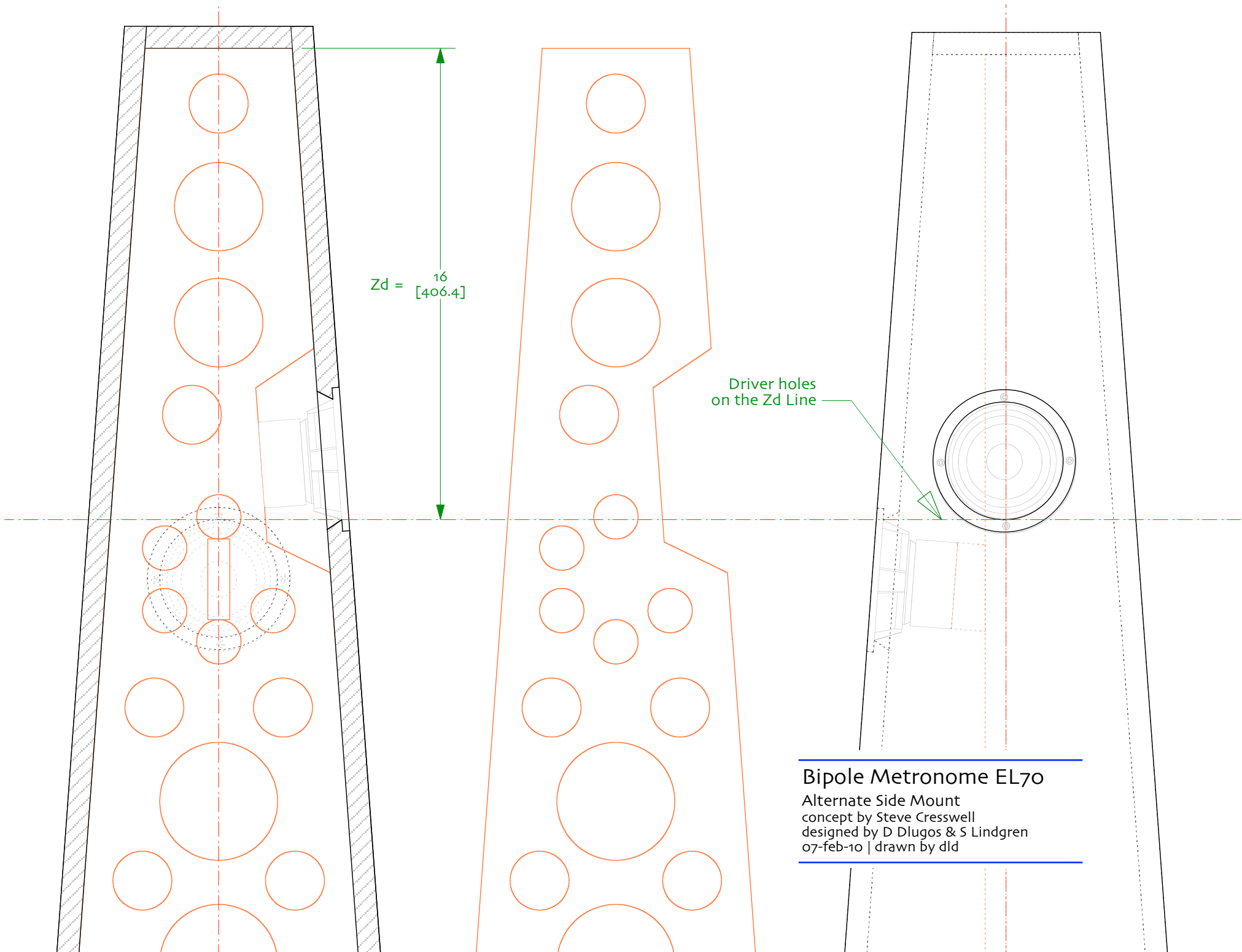

Bipole Metronome EL70

Alternate Side Mount
concept by Steve Cresswell
designed by D Dlugos & S Lindgren
07-feb-10 | drawn by dld

Bipole Metronome EL70

5' x 5' Cut Sheet
concept by Steve Cresswell
designed by D Dlugos & S Lindgren
09-feb-10 | drawn by dld

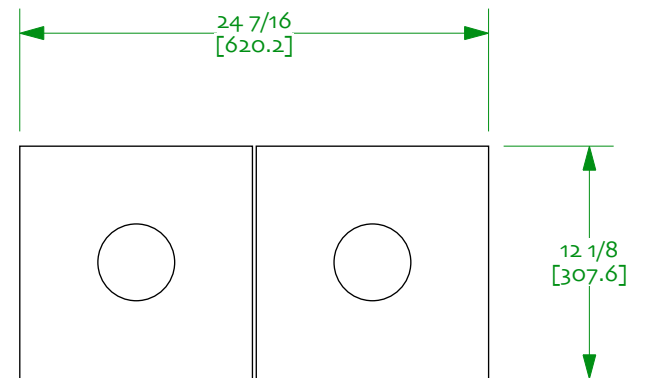
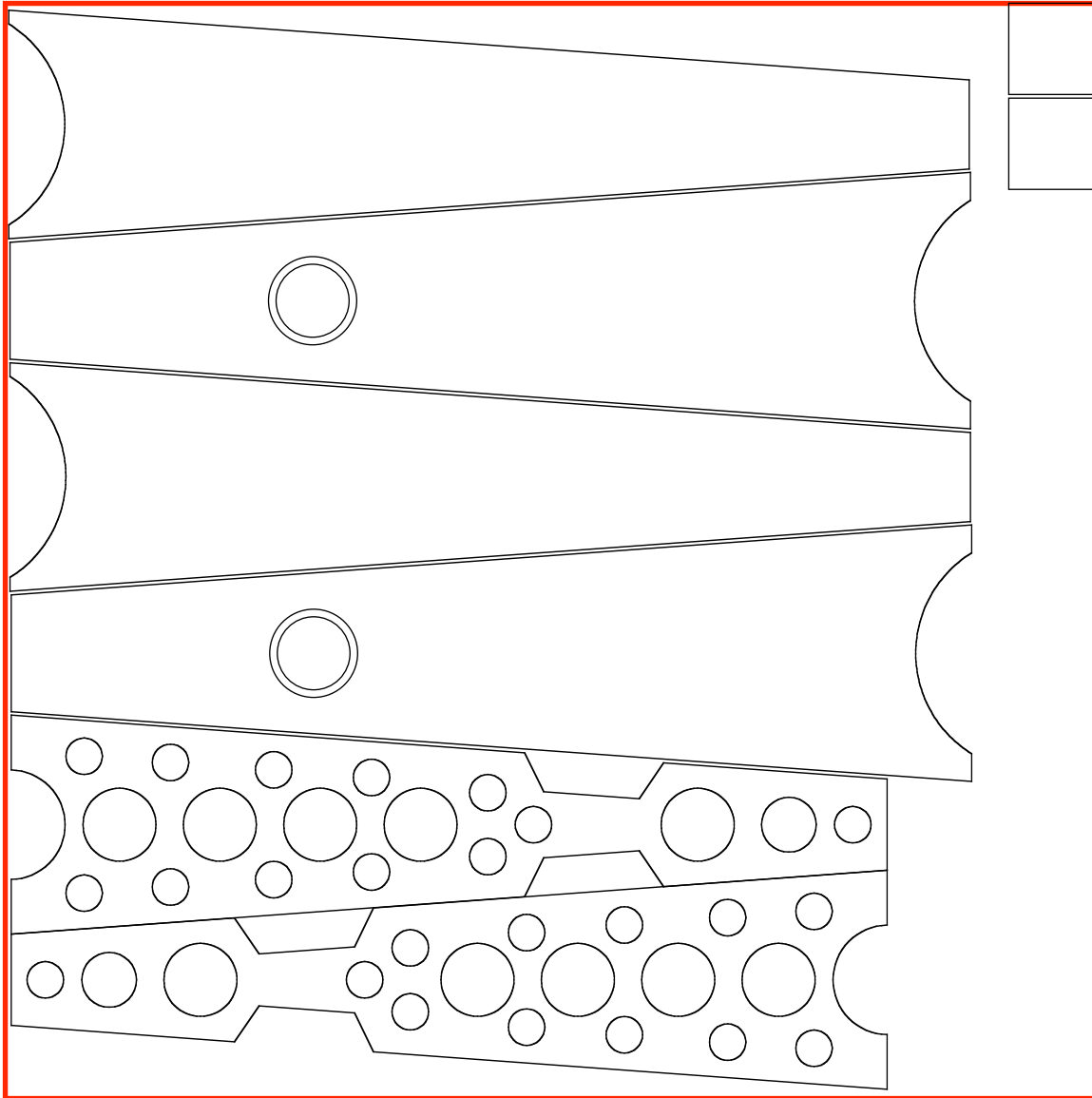

Bipole Metronome EL70

4' x 8' Cut Sheet
concept by Steve Cresswell
designed by D Dlugos & S Lindgren
09-feb-10 | drawn by dld

